

# Ultrasonic Plastic Welder Manual

(JYD-H40S Multi-station Turntable Machine)



# Content

1. Introduction.....	4
2. Safety Tips.....	4
3. Installation Position.....	5
4. Power Supply.....	5
5. Welding Principle.....	6
6. Diagram of machine parts.....	7
7. Power supply/connection port.....	7
7.1 Power supply.....	8
7.2 Power connection interface/external control input/output interface.....	8
7.3 Input/output control interface (C1, C2, C3).....	8
7.4 Input/output control interface (DB25) .....	9
7.5 Power connection interface/external control input/output interface (Table 1).....	10
8. Port wiring.....	10
8.1 Control input port.....	10
8.2 Work state output port.....	11
8.3 Analogue quantity input/output port.....	12
8.4 Communication port.....	12
8.5 HMI (human machine interface) communication port.....	12
9. Power specification.....	13
10. Operation interface.....	13
10.1 Password keyboard and parameter keyboard.....	13
11. Version information interface.....	14
11.1 Main interface.....	14
11.2 Welding record interface.....	15
11.3 Data management.....	15
11.4 Trigger preparation interface.....	16
11.4.1 Introduction of Film Rolling Machine.....	17
11.5 Interface functions and parameter scope.....	17
11.6 Parameter setting interface.....	17
11.7 Interface functions and parameter scope.....	18
11.8 Quality management interface.....	18

11.8.1 Interface functions and parameter scope.....	19
11.9 Protection function interface.....	19
11.9.1 Interface functions and parameter scope.....	19
11.10 Factory setting interface.....	20
11.10.1 Interface functions and parameter scope.....	20
11.11 Amplitude calibration interface.....	21
11.11.1 Interface functions and parameter scope.....	21
12. Troubleshooting.....	22
13. Quality assurance.....	24
14. Additional Explanation.....	25
15. Contact Us.....	25

# 1. Introduction

Dear Users,

Thank you for choosing JYD-H40S ultrasound product. It is an intelligent digital ultrasound welding machine researched and developed by us. We use perfect and optimized real-time phase-locked loop tracking technology in developing this series, which achieves more stable and reliable operation. Flexible human-machine interface configuration gains more flexible product application.

Before installing and using the product, please carefully read through the operation manual and get familiar with product operating specifications and applicable parameter scope.

No professional or non-professional technician without being trained or authorized by our company cannot debug or maintain this product without permission; Any improper operation will cause operation failure, fault or irreversible damage, and may even cause safety accident.

## 2. Safety Tips

Please carefully read through this manual before operating the equipment, for the sake of normal equipment operation and self-safety as well.

This manual shall be conveniently accessible to operation and maintenance personnel to read through.

The product has to be installed by professional technicians.

Operators have to take proper operation specification trainings. It is necessary to take corresponding protection measures to use the product on occasions where dangerous explosion may occur.

Since partial energy will be converted into heat during ultrasound welding, it is required to make sure that accumulated heat will not cause possibility of explosion or burning under conditions where no corresponding measure is taken.

Electro-magnetic compatibility of surrounding electric equipment shall meet the requirements in relevant national standards.

Users may make necessary setting to operation parameters, but set those with encrypted protection according to delivery default or this manual. If any question, please contact with our technicians.

Under no circumstance shall the equipment be started when the mold is loose.

If there is any abnormal condition and the fault is not solved, please do not re-start to avoid fault spreading.

Equipment movement or maintenance has to be conducted by professional technician with the equipment fully powered off.

Generator shall be blown by filtered dry compressed air for dedusting or swept by brush during maintenance. Please do not use cleanser or spray to clean generator enclosure and LCM interface which shall be wiped by cloth wet by water.

High-frequency load-driving cables and cables controlling and monitoring signals shall be stranded wires with shielding. Please do not stay too close to installation site of energized equipment and large-current conductors.

Shielded wires shall be connected to grounding wire end controlling power source.

Grounding wire end of all drive wires and control wires shall be connected to ground terminal, and ground terminal of generator shall be directly connected to grounding wire end of power supply source with conductors.

Attention shall be frequently paid to fault information code indicated by power source, and corresponding measures shall be taken earlier to avoid fault spreading.

Power source shall be installed in correct direction, stable with no looseness.

Make sure power supply specifications meet requirements for power supply

Do not roll up high-frequency load driving cables and temperature sensor wires if they are too long for installation, because this will cause over-high temperature and influence measurement precision. Connecting wires shall be shortened to required length.

Data parameters and function settings shall be recorded and filed after installation and debugging for reference if necessary. Cables connected to power supply cannot be randomly changed.

If any of the following conditions occurs, maintenance can be conducted by professional technical engineers when generator is fully powered off:

There is liquid or metal conductive object in power supply.

Power supply wires get loose or damaged.

Power supply gets loose.

Displayed power supply content is apparently different from standards for normal operation.

**Note: Please conduct maintenance with permission of technical supervisor.**

### **3. Installation Position**

Some power devices will cause heat when power supply works, over-high temperature rise will cause excessive protection in power supply (refer to description to "overheat" faults for details). We apply forced air cooling for this. Therefore, it is necessary to make sure that distance from generator air vent to surrounding shelter is not smaller than 10CM. Besides, it is still required to avoid being installed on sites with ambient temperature over 40°C and humidity over 75%.

### **4. Power Supply**

Power input specifications: AC 220V 50/60HZ. Try to use three-core cables with grounding wire to connect to generator power input connector. Please open the enclosure before replacing power protection fuse inside power supply.

## 5. Welding Principle

Ultrasonic welding is to convert 50/60 Hz current with ultrasonic generator into 15, 20, 30 or 40 KHz high-frequency power which is then output to piezoelectric ceramic of transducer to enable the transducer to produce mechanical shock of the same frequency which is transmitted to welding head through amplitude-change pole device. Welding head transmits received vibration energy to joint part of workpieces to be welded, and vibration energy is then converted into heat through friction to weld products in this area.

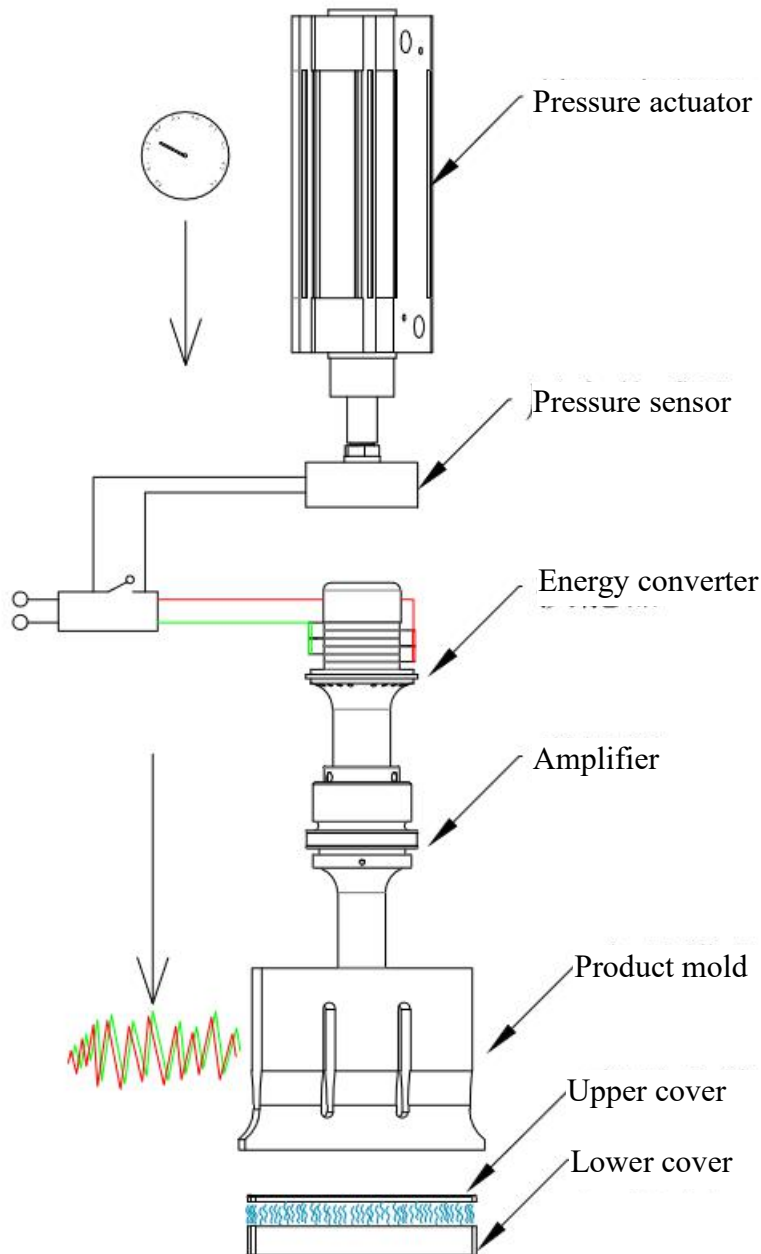

# 6. Diagram of machine parts

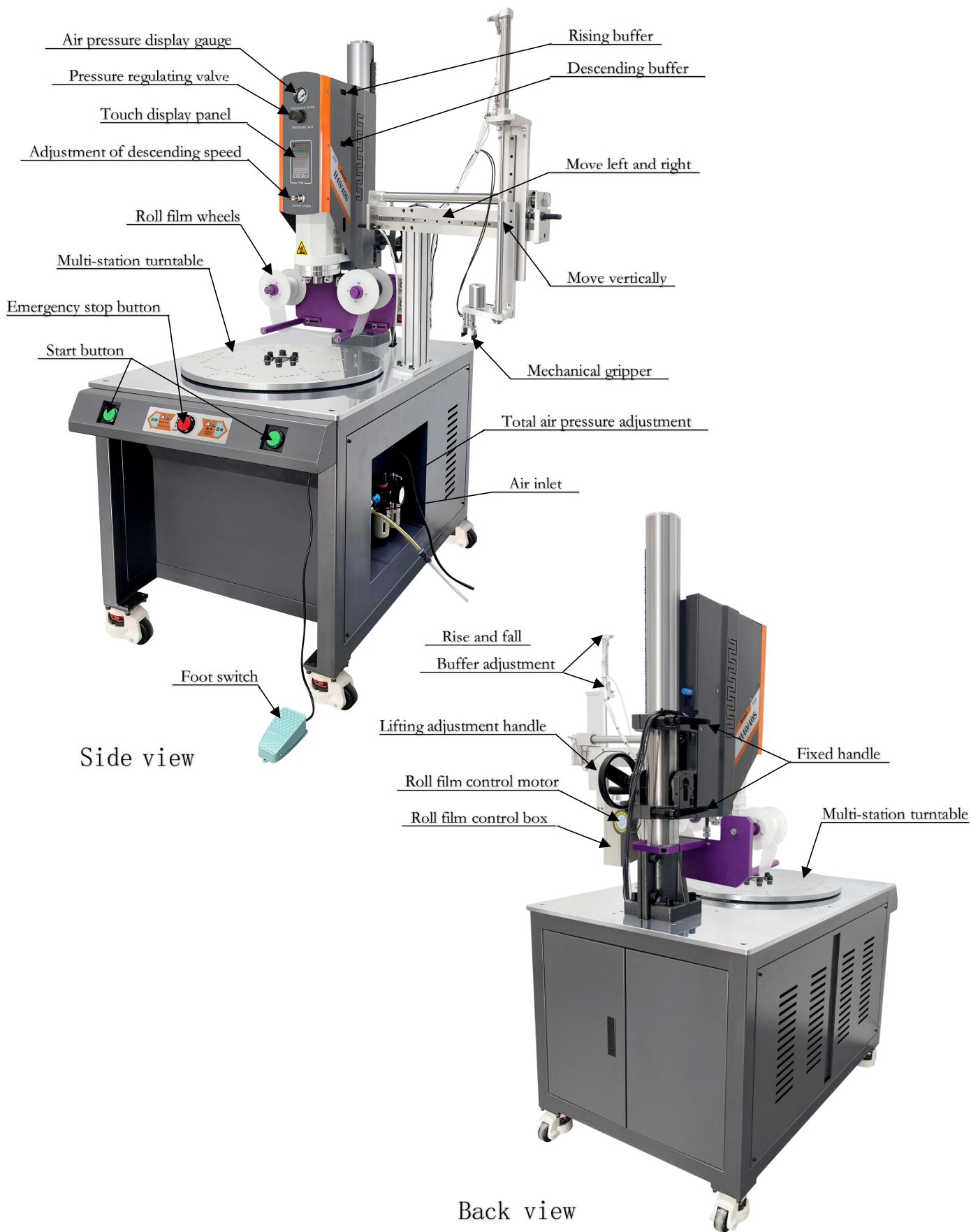

## 7. Power supply/connection port

### 7.1 Power supply

Power input specification: AC 220V 50/60HZ.

### 7.2 Power connection interface/external control input/output interface

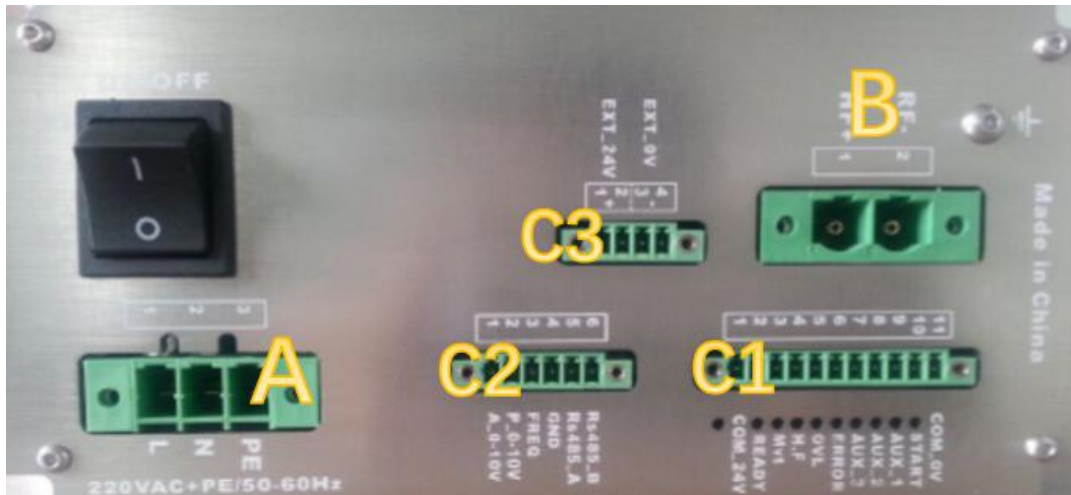

Note: Please connect power input with three-core cables for grounding, with cable diameter not smaller than 1.5mm

#### 7.2.1 Power input interface (A)

A: L 220VAC power supply live wire

B: N 220VAC power supply neutral line

C: PE power ground wire

Attention: Please connect the power input with three-core cable with ground wire, and the line diameter is not less than 1.5 mm<sup>2</sup>.

#### 7.2.2 High-frequency output interface (B)

A : HF+: Connect to the "+" terminal of the transducer

B : RF-: Connect to the "-" end of the transducer

Note: Please connect with shielded wire, withstand voltage  $\geq 2000V$ .

## 7.3 Input/output control interface (C1, C2, C3)

### 7.3.1 C1 port

1. COM\_24V: 24V power output common terminal

2.READY: ready to output

3.Mvt: cooling or cylinder action output

4.H.F: Ultrasonic work output

5.OVL: Overrun output

6.ERROR: fault warning output

7.AUX\_3: Multiplex port 3 input

- 8.AUX\_2: Multiplexed port 2 input
- 9.AUX\_1: multiplex port 1 input
- 10.START: work start input
- 11.COM\_0V: 0V power input common terminal

### 7.3.2 C2 port

- 1.A\_0-10V: External analog amplitude modulation input
- 2.P\_0-10V: Real-time power output
- 3. FREQ: Frequency pulse output
- 4. GND: Internal power ground
- 5.RS485\_A: RS485 communication A port
- 6. RS485\_B: RS485 communication B port

### 7.3.3 C3 port

- 1 2 EXT\_24V: 24V power supply
- 3 4 EXT\_0V: 0V power supply

Note: When the input and output common ports are not enough, they can be connected to port C3. The 24V power supply of port C3 and the common power supply of port C1 are internally connected together.

## 7.4 Input/output control interface (DB25)

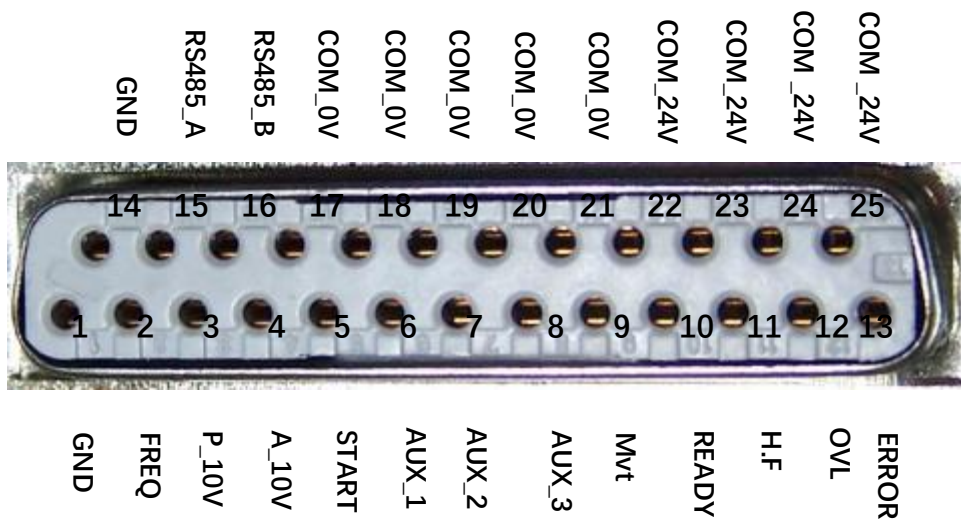

## 7.5 Power connection interface/external control input/output interface (Table 1)

Pin	Name	Status	Description
C1_10	Start	Input port	Ultrasonic starting (Note 1)
C1_9	AUX_1		Standard machine model: Ultrasonic searching; Program control model: Trigger ultrasonic starting (Note 2)
C1_8	AUX_2		Standard machine model: Amplitude grading; Program control model: Emergency stop (Note 3)
C1_7	AUX_3		Standard machine model: Vibration control; Program control model: Grounding detection (Note 4)
C1_11	COM_0V		Public end of input port
C1_2	READY	Output port	"Ready" state output
C1_3	Mvt		"Curing" state output (Note 5)
C1_4	H.F		"Ultrasonic work" state output (Note 6)
C1_5	OVL		"Overload" state output (press resetting button or ultrasonic searching input to eliminate the state)
C1_6	ERROR		"Fault" state output (Note 7)
C1_1	COM_24V		Public end of output port
C3_1,C3_2	24V	External control power supply	24V output + pole (24V/1A) (Note 8)
C3_3,C3_4	0V		24V output - pole (Note 8)
C2_1	A 0_10V	Amplitude control	Amplitude control input 0-10V (10-100% amplitude)
C2_2	P 0_10V	Power output	Power output 0-10V (10-100% rated power)
C2_3	FREQ	Frequency output	Frequency pulse output (3.3V/10mA)
C2_5	RS485_A	Communication port	RS485(MODBUS_RTU) communication interface
C2_6	RS485_B		
C2_4	GND	Internal power ground	Public land of internal power supply (public land of C2 port)

## 8. Port wiring

### 8.1 Control input port

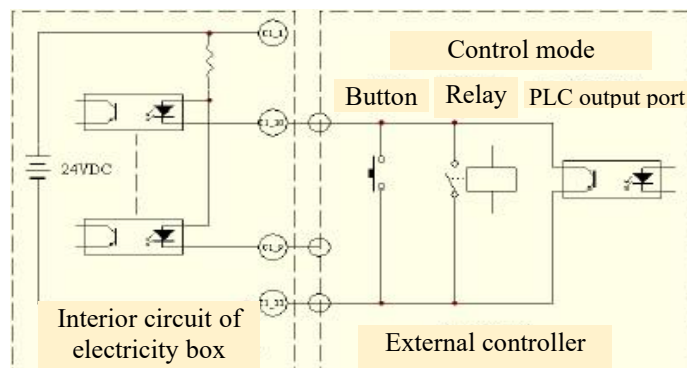

External trigger ^ ultrasonic starting

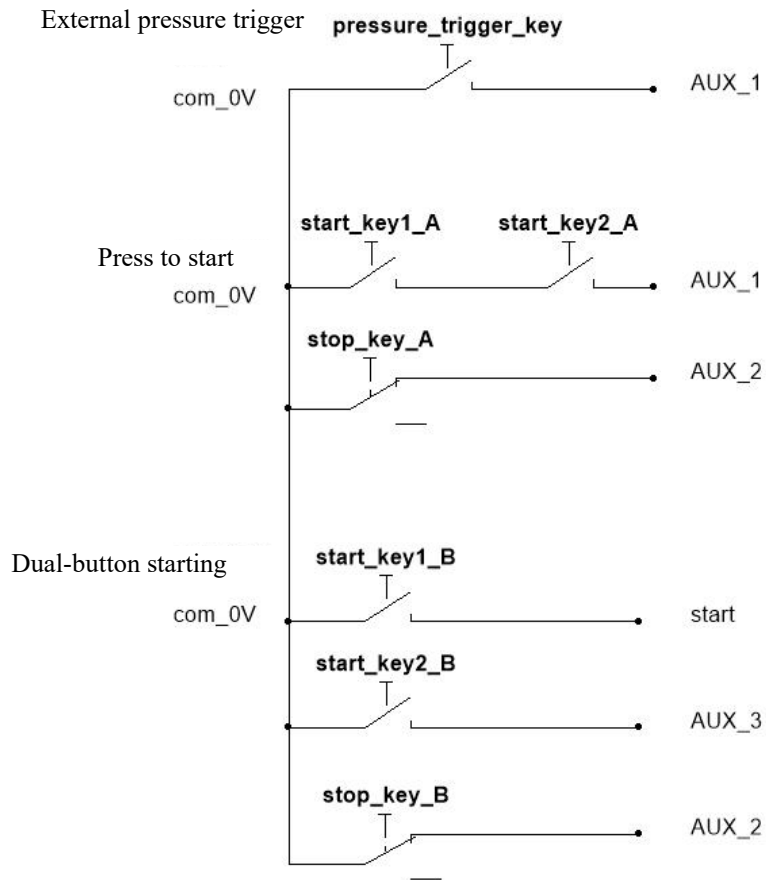

## 8.2 Work state output port

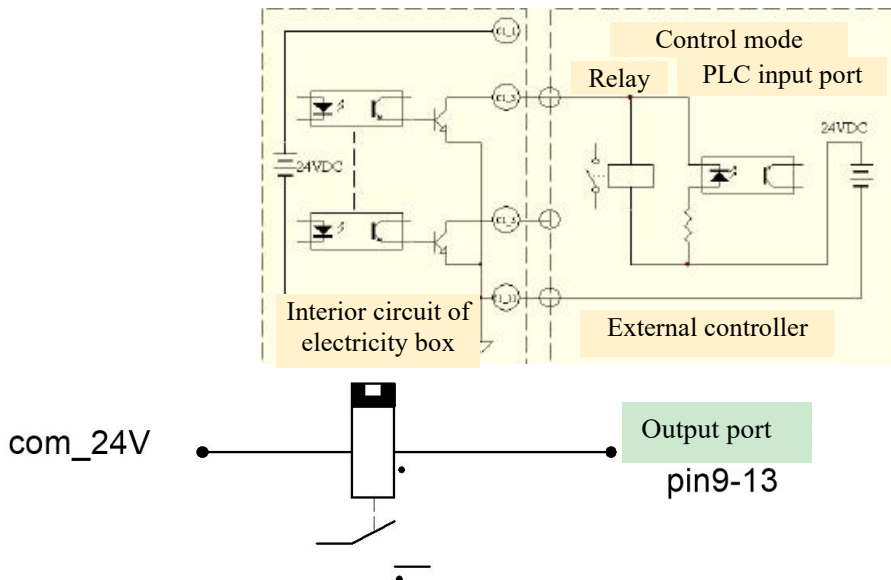

Note: The maximum driving current for 24V power input is 1A.  
Please use shielded wire as signal wire, with wire diameter  $\geq 0.3\text{mm}^2$  and length not exceeding 6m.

### 8.3 Analogue quantity input/output port

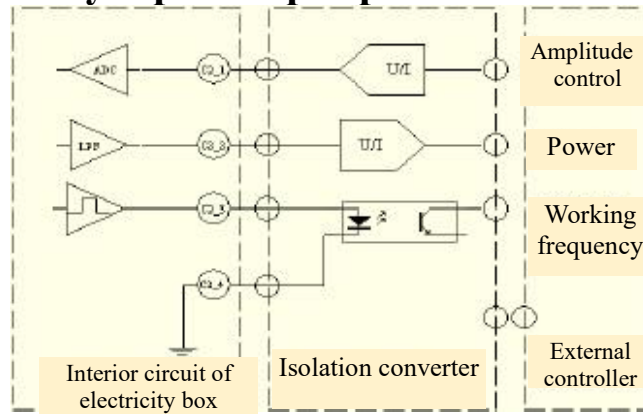

Note: Analogue quantity input and output ports have to be set with isolation switching circuits outside.  
Frequency port 3.3V/10mA TTL level output

### 8.4 Communication port

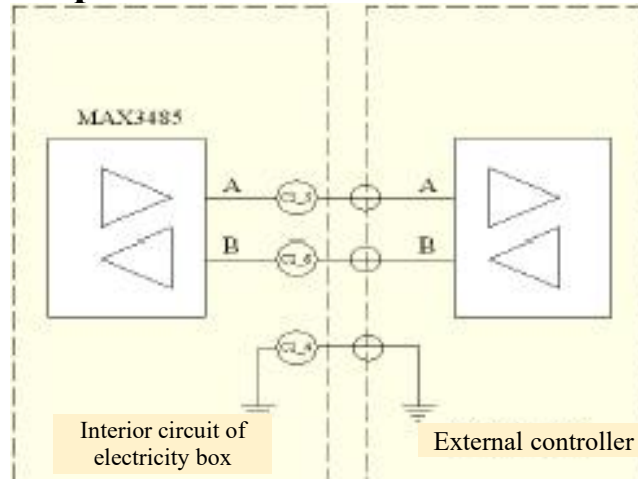

Note: RS485 communication interface shall be isolated on strong-interference site with shielded twisted pair.

### 8.5 HMI (human machine interface) communication port

Definition of communication wiring

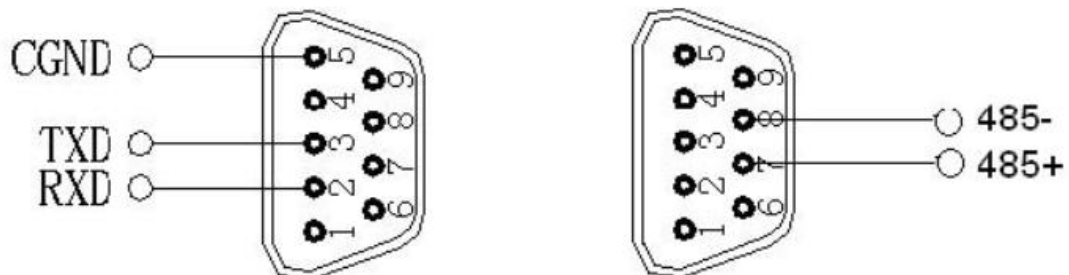

Note: Human-machine interface of the equipment applies RS485 communication, baud rate 57600, data format 8/N/1 and big-endian and little-endian.

## 9. Power specification

(Table 2)

<b>Model</b>	H40/40S				
<b>Power</b>	4000W	3000W	2200W	1200W	1000W
<b>Frequency</b>	15KHz	15KHz 20KHz	15KHz 20KHz	20KHz	35KHz
<b>Working voltage</b>	220VAC±10% 50-60Hz				
<b>Rated current</b>	12.9A	9.6A	6.5A	4.8A	3.2A
<b>Rated power</b>	4000W	3000W	2200W	1200W	1000W
<b>Peak power</b>	5600W	4200W	2400W	1800W	1500W
<b>Fuse protection current</b>	25A	25A	20A	15A	10A
<b>Ambient temperature</b>	-10 to +55°C				
<b>Protection level</b>	IP 20, IEC 60 529, EN 60 525				

## 10. Operation interface

In the following is the instruction to functions of JYD-H40/40S interface and operations:

### 10.1 Password keyboard and parameter keyboard.

**Password keyboard:** Password input keyboard has blue background, set with keys for figures, ±, resetting, exit and confirmation;



**Parameter keyboard:** Parameter keyboard has green background, set with keys for figure, backspace, resetting, exit and confirmation;



# 11. Version information interface

It skips from version information displayed at default after starting to welding record 6s later if no operation on the interface.

Version information interface displays rated power, rated frequency, version and date.

Click H40/40S icon to change basic passwords (initial password "1234")

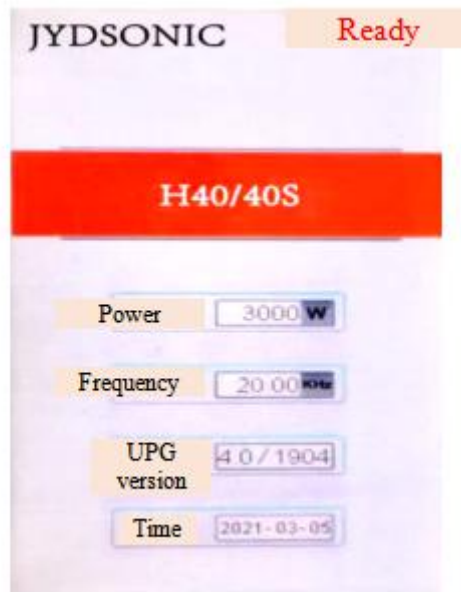

## 11.1 Main interface

At the top of display area is menu interface. Click the menu interface to choose, and click corresponding button to enter corresponding interfaces. Password to "Protective function" interface is "1962", "8080" to "Amplitude calibration" interface and "2005" to "Factory setting" interface.

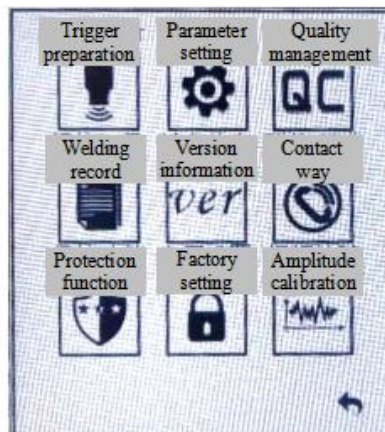

## 11.2 Welding record interface

Click "Welding" button in the Menu Bar to enter the interface.

The interface displays welding records, real-time welding energy and data management operations.

**Note:** Please do not shut down the equipment directly after finishing welding, and wait 40s to avoid loss of form data.



## 11.3 Data management

Click the bottom right corner on the interface to activate data management menu, and click corresponding buttons based on demands.

- Clear:** It starts to count from 1 again (unrecoverable), with recorded form data not deleted.
- Delete record:** Delete form data records (unrecoverable), with count value unchanged.
- Data export:** Click the button to output historical form data records after inserting in U disk.

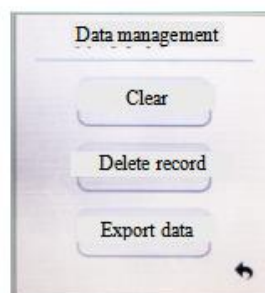

## 11.4 Trigger preparation interface

Click "Trigger preparation" button in the Menu Bar to enter the interface.

As a debugging interface, the interface can observe power, frequency and real-time impedance, set corresponding preset values, and choose settings of amplitude, trigger mode and others based on actual working conditions, use requirements for amplitude and using demands. The equipment temporarily stops after entering the interface, and switches to manual mode from automatic mode. Press external emergency stop button or interface to trigger preparation button for resetting.

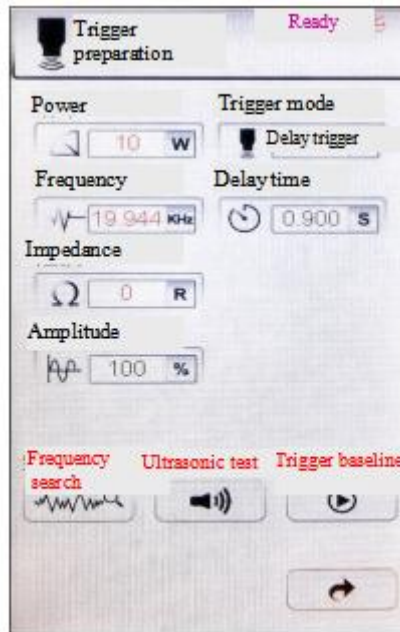

Enter the trigger preparation interface and click the return button in the lower right corner to enter the second page of the current function, which is in manual mode.

1. Vertical OFF: the vertical movement of the gripper, click again to return;
2. Level OFF: the lateral movement of the gripper, click again to return;
3. Station motor OFF: Click once on the desktop turntable to move to the next station, double-click it will keep rotating, and click again to stop;
4. Take blame OFF: The top cylinder will prevent the turntable from rotating after starting, click again to return;
5. Adsorb OFF: the grasping and releasing action of the gripper;
6. The quantity of materials received will be changed according to the production quantity;
7. "Receiving time" and "receiving step time" do not need to be changed.

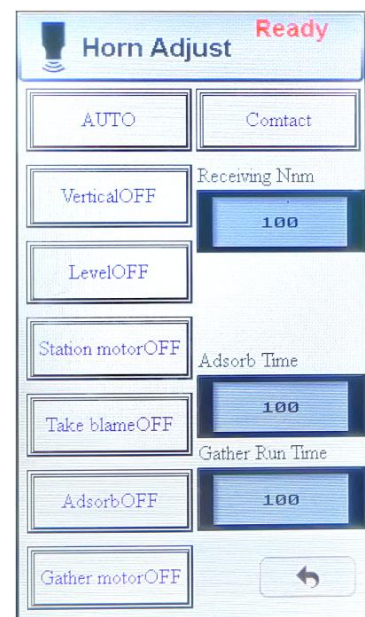

## 11.4.1 Introduction of Film Rolling Machine

1. Green button: Click once to roll the mold length once  
Press will keep rolling;
2. Upper dial: it shows the time of one roll film,  
manually rotate to adjust the time of other roll films;
3. The dial below: displays the delay time at the  
beginning of the film roll (generally not adjusted);
4. The rocker switch is independently switchable



## 11.5 Interface functions and parameter scope

- Selection of trigger mode:**
1. **Delay trigger:** Vibration delay 0-10S;
  2. **Pressure trigger:** External pressure switch;
- Frequency search:** Search real-time frequency (inching).
- Ultrasonic test:** Ultrasonic function test (long-pressing).
- Trigger baseline:** The equipment goes downward after starting to reach the trigger position for automatic resetting.
- Auxiliary mode:** Customize based on customer demands;

## 11.6 Parameter setting interface

Click "Parameter preparation" button in the Menu Bar to enter the interface.

The interface can choose trigger or working mode and set corresponding parameters.

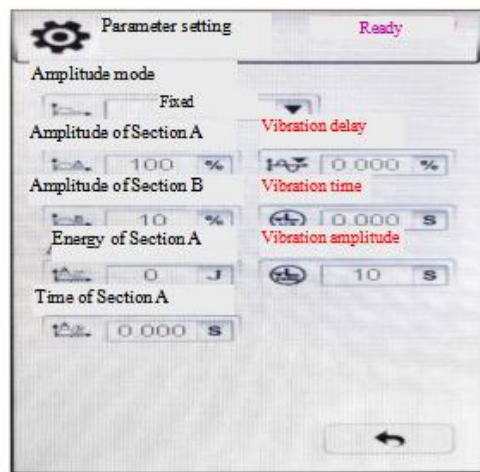

## 11.7 Interface functions and parameter scope

- Amplitude mode:**
1. Fixed: Single-amplitude mode, setting amplitude of Section A;  
Setting range: 10-100%;
  2. Grading: Dual-amplitude mode, displaying and setting amplitudes of Section A and B and proportion of Section A;  
Setting range: Amplitude of Section A: The same as fixed mode;  
Amplitude of Section B: 10-100%;  
Proportion of Section A: 10-100%.

Note: Proportion of Section B is not displayed, being "100%-proportion of Section A".

- Trigger mode:** The same as trigger preparation interface.
- Operating mode:**
1. **Time:** 0-10S;
  2. **Energy:** 0-6000J;
  3. **Time and energy.**
- Grounding maintenance:** 0-10S.
- Curing time:** Curing cooling lasts 0-10S after finishing welding.
- Vibration amplitude:** Ultrasonic secondary vibration amplitude is 10-100% after curing.
- Vibration delay:** Ultrasonic secondary vibration delay is 1-10S.
- Vibration time:** Ultrasonic secondary vibration time is 1-10S, and secondary vibration is prohibited when it is set as 0S.

## 11.8 Quality management interface

Click "Quality management" button in the Menu Bar to enter the interface. The interface can turn on/off corresponding quality management switches and set quality monitoring scope; (The time quality management in the figure is turned on, and energy quality management switch turned off).



## 11.8.1 Interface functions and parameter scope

Period: 0-10/S.

Energy: 0-60000/J.

Note: When the maximum value is zero, it is required to set the maximum value first.

## 11.9 Protection function interface

Click the "Protection function" button in the Menu Bar to enter the interface, and the password to the interface is "1962".

The interface can set corresponding protection parameters.

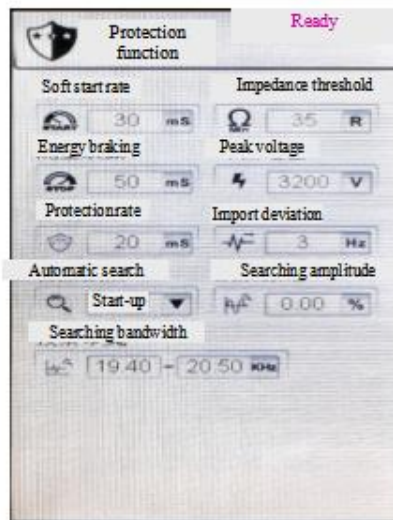

### 11.9.1 Interface functions and parameter scope

**Automatic search:** Prohibited, startup, 1 time/minute, 3 times/minute, 5 times/minute, 7 times/minute, 9 times/minute. It automatically calibrates frequency to prevent frequency deviation during standby.

Searching amplitude: 0-1%.

Searching bandwidth Min: 0-13KHz.

Searching bandwidth Max: Min-70KHz.

**Soft start rate:** 10-2000mS. For ultrasonic soft start speed, the larger the figure is, the slower the soft start will be.

**Energy braking:** 10-2000mS. For ultrasonic soft shutdown speed, the larger the figure is, the slower the shutdown will be.

**Protection rate:** 1-100mS. For protection reaction speed, the smaller the figure is, the more flexible the protection will be.

Peak current: 1-25A.

Peak voltage: 500-4000V.

Zero-load impedance: 15-100Ω.

Frequency shift: 0-99Hz.

## 11.10 Factory setting interface

Password to "Factory setting" interface is "2005".

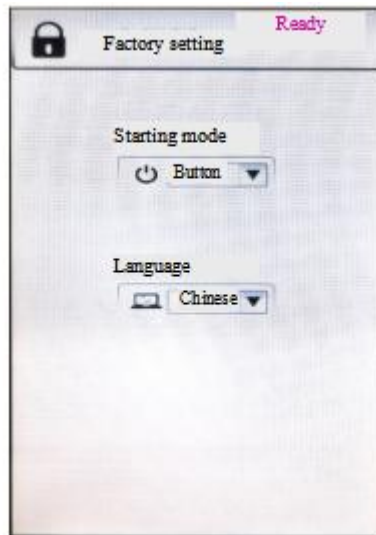

### 11.10.1 Interface functions and parameter scope

**Startup mode:** Button, PLC and double-button.

**Language selection:** Chinese and English

## 11.11 Amplitude calibration interface

Password to the "Amplitude calibration" interface is "8080".

Constant amplitude debugging steps: 1. Choose "calibration" as constant amplitude function; 2. Amplitude is set as 100%; 3. Long press ultrasonic testing button; 4. Observe system parameters and constant amplitude data; 5. Input the minimum and maximum values of observed constant amplitude data within the constant amplitude scope; 6. Choose "Allowed" for constant amplitude function.

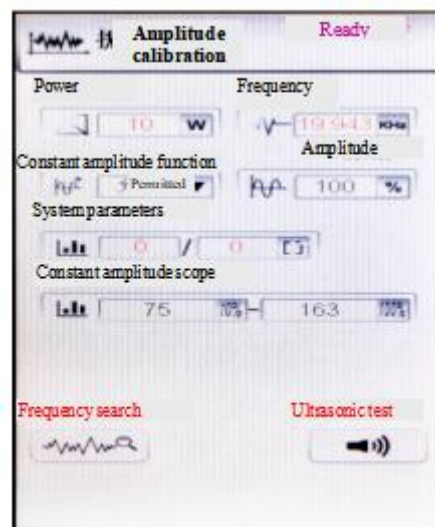

### 11.11.1 Interface functions and parameter scope

<b>Frequency search:</b>	The same as trigger preparation interface.
<b>Ultrasonic test:</b>	The same as trigger preparation interface.
<b>Constant amplitude function:</b>	Allowed, calibration and prohibited.
<b>Constant amplitude scope:</b>	Min20-Max999.

# 12. Troubleshooting

## 12.1 Abnormal communication

**Fault cause:**

Poor contact of communication wiring cable;  
Damage on communication chip in control panel;  
Unstable power supply.

**Corresponding solutions:**

Check communication wiring cables or combination sockets;  
Replace with control panel of the same specifications;  
Re-power on for resetting

## 12.2 Functional limit

**Fault cause:**

Users adjust control panel or other applications without permission from supplier;  
Parameter setting error;  
Abnormal initialization of system data storage.

**Corresponding solutions:**

Contact the supplier.  
Reset data.

## 12.3 Poor quality

**Fault cause:**

Suspected defective product.

**Corresponding solutions:**

Press emergency stop button to reset, and check and identify workpieces, molds or equipment problems before continuously processing.

## 12.4 Temperature rise is too high

**Fault cause:**

Cooling fan gets damaged or cooling air duct blocked;  
Higher mold impedance, causing abnormal rising of output power.

**Corresponding solutions:**

Replace air fan and check cooling air duct;  
Check molds, and start ultrasonic test to determine whether mold impedance is normal.

## **12.5 Abnormal load**

### **Fault cause:**

Transducer wiring cable gets loose or disconnected;  
Transducer is affected with damp or positive and negative electrodes are wired wrongly.

### **Corresponding solutions:**

Press interface resetting button to search for frequency;  
Check transducer or connecting cables.

## **12.6 Frequency overrun**

### **Fault cause:**

Mold temperature rising leads to frequency deviated beyond the maximum working bandwidth;

Loose or damaged mold leads to out-of-tune frequency locking.

### **Corresponding solutions:**

Press interface resetting button to search for frequency;  
Cool molds to normal temperature range;  
Check molds, and start ultrasonic test to determine whether mold impedance is normal.

## **12.7 Power overload**

### **Fault cause:**

Output power goes beyond the rated power scope.

### **Corresponding solutions:**

Press interface resetting button to search for frequency;  
Reduce amplitude or load (such as reducing air pressure);  
Replace with ultrasonic power supply of higher power.

## **12.8 Over high voltage and current**

### **Fault cause:**

Peak voltage at two ends of transducer goes beyond the allowable scope;  
Mold impedance is over large or overloaded.

### **Corresponding solutions:**

Press interface resetting button to search for frequency  
Check molds, and start ultrasonic test to determine whether mold impedance is normal.  
Reduce amplitude or load (such as reducing air pressure);  
"Protection sensitivity" can be properly increased for accidental protection.  
"Peak voltage" can be properly increased for frequent protection.

## **12.9 Relatively higher mould impedance**

### **Fault cause:**

Mould impedance test goes beyond the allowable scope;  
Overload during ultrasonic test (such as workpiece is pressed when the test starts).

### **Corresponding solutions:**

Press interface resetting button to search for frequency  
Check mould and modify;  
Zero-load ultrasonic test;  
"Zero-load impedance threshold" can be properly increased for loaded testing conditions (such as energy collecting bar).

**Note:** If the above corresponding fault solutions fail to clear faults, it may be fault inside generator. If so, please contact us.

## **13. Quality assurance**

**Quality guarantee for this product shall be subject to the following regulations:**

**Warranty only covers generator body, and warranty period starts from the Company's delivery date. Warranty period is twelve months after purchase. Faults caused by the following reasons belong to paid repair, even within the period warranty:**

- 1. Problems caused by incorrect operation or repair and modification without permission;**
- 2. Problems caused by using beyond requirements in standards and specifications;**
- 3. Damage caused by falling or rude handling after purchase;**
- 4. Component aging or fault caused by using in environment not meeting requirements in the Manual;**
- 5. Equipment damage caused by foreign matters entering outside (such as insect);**
- 6. Equipment damage caused by wiring error;**
- 7. Faults caused by earthquake, fire, geomantic disaster, lightning strike, abnormal voltage or other natural disasters and causes accompanying with disasters.**

**The Company is entitled to entrust others for repair for products involved in faults.**

**Quality warranties under responsibility of the Company, using in China:**

- a. Warranty within twelve months after delivery.**
- b. All sales and agency institutions of the Company all over the country can provide after-sales services.**

## **14. Additional Explanation**

**About disclaimer:**

- 1. The Company does not undertake responsibilities caused or induced by using the product violating the Manual.**
- 2. The Company does not undertake responsibility for compensation against losses or impacted and secondary damages caused to you by faults of the product.**

**Notice for use:**

**The Company undertakes lifelong responsibilities for the product, and provides with all services related to the product.**

**Although the product is designed and manufactured under strict quality control, please be sure to ask us about using purposes where its fault or mis-operation may endanger human body or other lives.**

## **15. Contact Us**

**Hotline: 0769-83506468**

**The Company reserves the right to modify the Manual without previous notice; If any question or problem, please contact with us in time. Your suggestions are warmly welcomed.**