

Ultrasonic Plastic Welder

Manual

(JYD-H60/H60S)



Contents

1. Introduction.....	4
2. Safety Tips.....	4
3. Installation Position.....	5
4. Power Supply.....	5
5. Welding Principle.....	6
6. Diagram of machine parts.....	7
7. Power supply/connection port.....	8
7.1 Power Supply.....	8
7.2 Power supply connecting interface/external control input/output interface.....	8
7.3 Input/output control interface (DB25)	8
7.4 Power connection interface/external control input/output interface (Table 1).....	9
8. Port wiring.....	9
8.1 Control input port.....	9
8.2 Work state output port.....	10
8.3 Analogue quantity input/output port.....	11
8.4 Communication port.....	11
8.5 HMI (human machine interface) communication port.....	12
9. Power specification.....	13
10. Operation interface.....	13
10.1 Password keyboard and parameter keyboard.....	13
10.2 Version information interface.....	14
10.3 Welding record interface.....	14
10.3.1 Data management.....	15
10.4 Trigger preparation interface.....	15
10.4.1 Interface functions and parameter scope.....	16
10.5 Parameter setting interface.....	17
10.5.1 Interface functions and parameter scope.....	17
10.6 Quality management interface.....	18
10.6.1 Interface functions and parameter scope.....	18
10.7 Protection function interface.....	18
10.7.1 Interface functions and parameter scope.....	19
10.8 Factory setting interface.....	19

10.8.1 Interface functions and parameter scope.....	20
10.9 Amplitude calibration interface.....	20
10.9.1 Interface functions and parameter scope.....	21
10.10 Contact information interface.....	21
10.10.1 Interface function.....	22
11. Troubleshooting.....	22
12. Quality assurance.....	26
13. Additional Explanation.....	26
14. Contact Us.....	27

1. Introduction

Dear Users,

Thank you for choosing JYD-H60/H60S ultrasound product. It is an intelligent digital ultrasound welding machine researched and developed by us. We use perfect and optimized real-time phase-locked loop tracking technology in developing this series, which achieves more stable and reliable operation. Flexible human-machine interface configuration gains more flexible product application.

Before installing and using the product, please carefully read through the operation manual and get familiar with product operating specifications and applicable parameter scope.

No professional or non-professional technician without being trained or authorized by our company cannot debug or maintain this product without permission; Any improper operation will cause operation failure, fault or irreversible damage, and may even cause safety accident.

2. Safety Tips

Please carefully read through this manual before operating the equipment, for the sake of normal equipment operation and self-safety as well.

This manual shall be conveniently accessible to operation and maintenance personnel to read through.

The product has to be installed by professional technicians.

Operators have to take proper operation specification trainings. It is necessary to take corresponding protection measures to use the product on occasions where dangerous explosion may occur.

Since partial energy will be converted into heat during ultrasound welding, it is required to make sure that accumulated heat will not cause possibility of explosion or burning under conditions where no corresponding measure is taken.

Electro-magnetic compatibility of surrounding electric equipment shall meet the requirements in relevant national standards.

Users may make necessary setting to operation parameters, but set those with encrypted protection according to delivery default or this manual. If any question, please contact with our technicians.

Under no circumstance shall the equipment be started when the mold is loose.

If there is any abnormal condition and the fault is not solved, please do not re-start to avoid fault spreading.

Equipment movement or maintenance has to be conducted by professional technician with the equipment fully powered off.

Generator shall be blown by filtered dry compressed air for dedusting or swept by brush during maintenance. Please do not use cleanser or spray to clean generator enclosure and LCM interface which shall be wiped by cloth wet by water.

High-frequency load-driving cables and cables controlling and monitoring signals shall be stranded wires with shielding. Please do not stay too close to installation site of energized equipment and large-current conductors.

Shielded wires shall be connected to grounding wire end controlling power source.

Grounding wire end of all drive wires and control wires shall be connected to ground terminal, and ground terminal of generator shall be directly connected to grounding wire end of power supply source with conductors.

Attention shall be frequently paid to fault information code indicated by power source, and corresponding measures shall be taken earlier to avoid fault spreading.

Power source shall be installed in correct direction, stable with no looseness.

Make sure power supply specifications meet requirements for power supply

Do not roll up high-frequency load driving cables and temperature sensor wires if they are too long for installation, because this will cause over-high temperature and influence measurement precision. Connecting wires shall be shortened to required length.

Data parameters and function settings shall be recorded and filed after installation and debugging for reference if necessary. Cables connected to power supply cannot be randomly changed.

If any of the following conditions occurs, maintenance can be conducted by professional technical engineers when generator is fully powered off:

There is liquid or metal conductive object in power supply.

Power supply wires get loose or damaged.

Power supply gets loose.

Displayed power supply content is apparently different from standards for normal operation.

Note: Please conduct maintenance with permission of technical supervisor.

3. Installation Position

Some power devices will cause heat when power supply works, over-high temperature rise will cause excessive protection in power supply (refer to description to "overheat" faults for details). We apply forced air cooling for this. Therefore, it is necessary to make sure that distance from generator air vent to surrounding shelter is not smaller than 10CM. Besides, it is still required to avoid being installed on sites with ambient temperature over 40°C and humidity over 75%.

4. Power Supply

Power input specifications: AC 220V 50/60HZ. Try to use three-core cables with grounding wire to connect to generator power input connector. Please open the enclosure before replacing power protection fuse inside power supply.

5. Welding Principle

Ultrasonic welding is to convert 50/60 Hz current with ultrasonic generator into 15, 20, 30 or 40 KHz high-frequency power which is then output to piezoelectric ceramic of transducer to enable the transducer to produce mechanical shock of the same frequency which is transmitted to welding head through amplitude-change pole device. The welding head transmits the received vibration energy to the joint part of workpieces to be welded. In this area, the vibration energy makes the surfaces of the two objects rub against each other to form the fusion between the molecular layers and the products are welded.

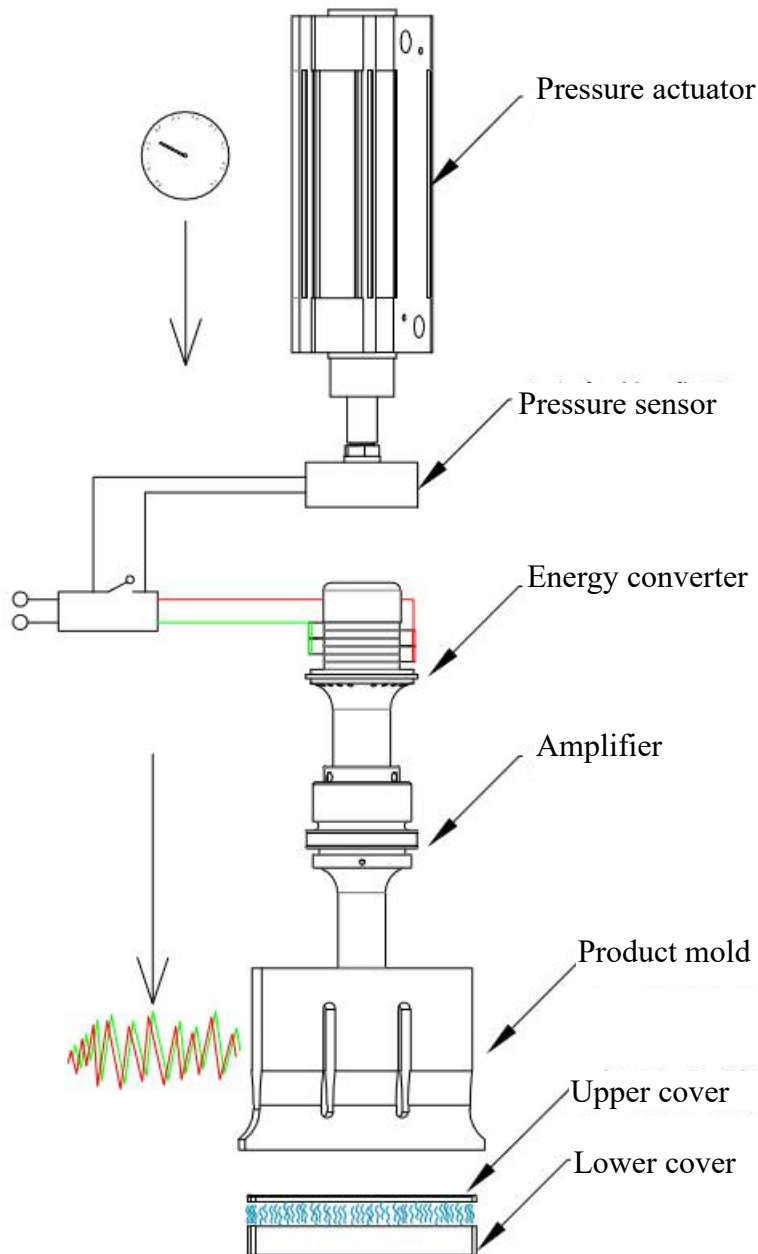

6. Diagram of machine parts



Side view

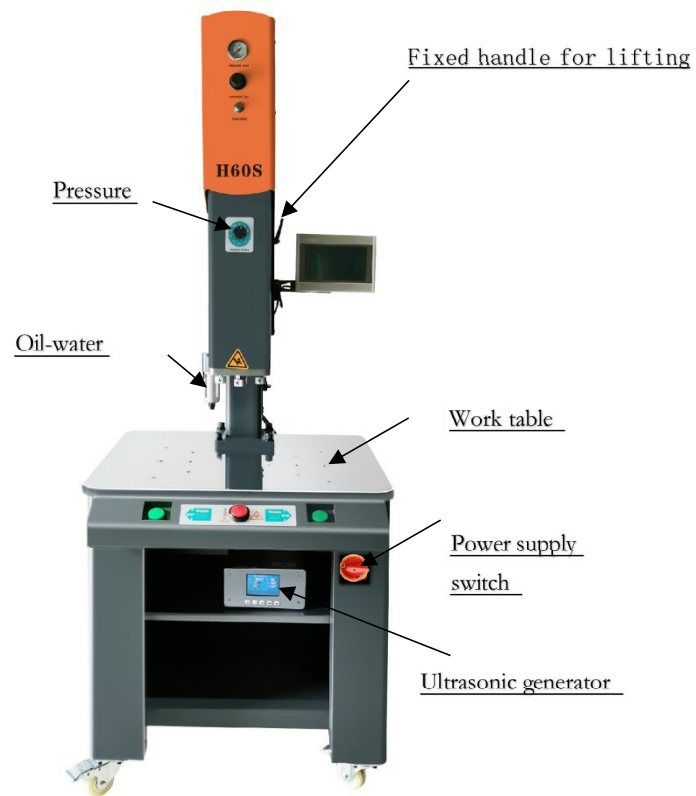

Front view

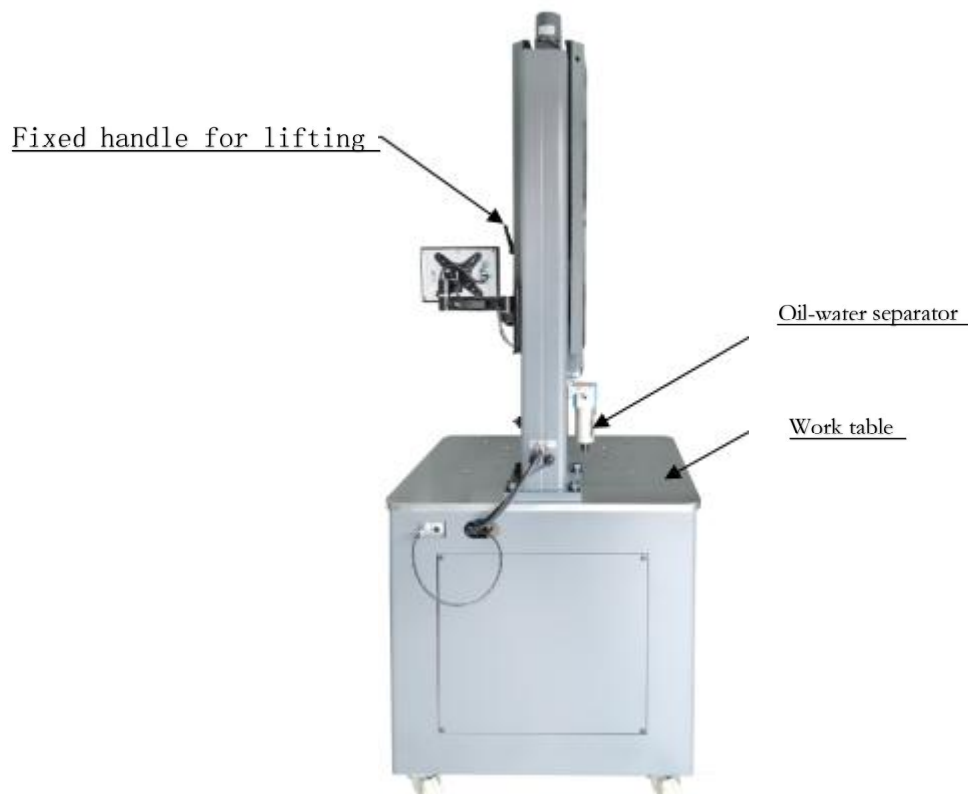

Rear view

7. Power supply/connection port

7.1 Power Supply

Power input specifications: AC 220V 50/60HZ.

7.2 Power supply connecting interface/external control input/output interface

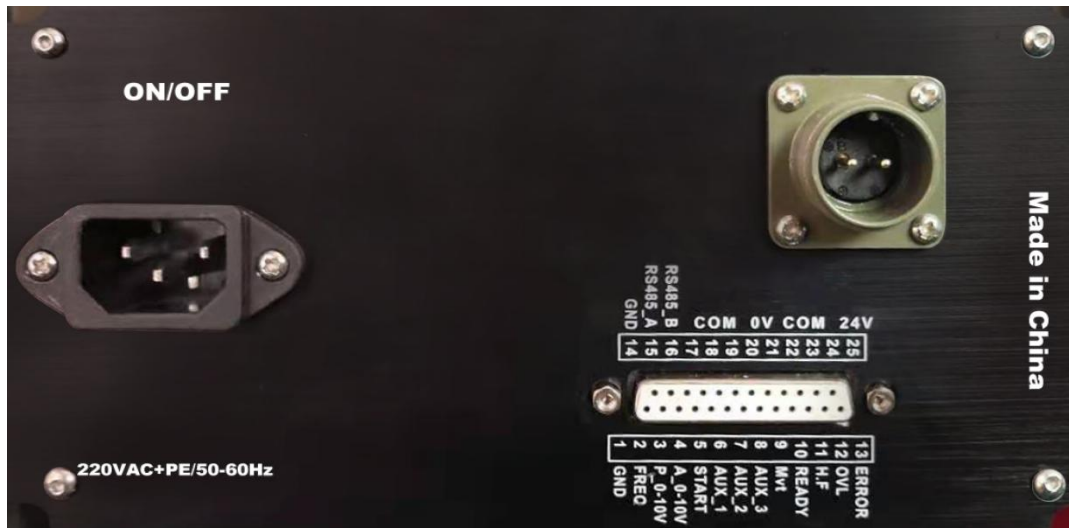

7.3 Input/output control interface (DB25)

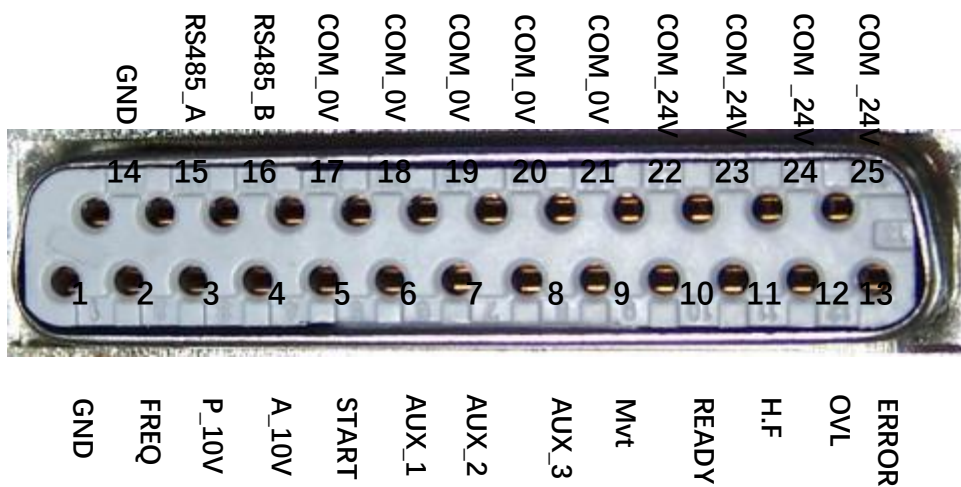

7.4 Power connection interface/external control input/output interface (Table 1)

Pin	Name	Status	Description
C1_10	Start	Input port	Ultrasonic starting (Note 1)
C1_9	AUX_1		Standard machine model: Ultrasonic searching; Program control model: Trigger ultrasonic starting (Note 2)
C1_8	AUX_2		Standard machine model: Amplitude grading; Program control model: Emergency stop (Note 3)
C1_7	AUX_3		Standard machine model: Vibration control; Program control model: Grounding detection (Note 4)
C1_11	COM_0V		Public end of input port
C1_2	READY	Output port	"Ready" state output
C1_3	Mvt		"Curing" state output (Note 5)
C1_4	H.F		"Ultrasonic work" state output (Note 6)
C1_5	OVL		"Overload" state output (press resetting button or ultrasonic searching input to eliminate the state)
C1_6	ERROR		"Fault" state output (Note 7)
C1_1	COM_24V		Public end of output port
C3_1,C3_2	24V	External control power supply	24V output + pole (24V/1A) (Note 8)
C3_3,C3_4	0V		24V output - pole (Note 8)
C2_1	A 0_10V	Amplitude control	Amplitude control input 0-10V (10-100% amplitude)
C2_2	P 0_10V	Power output	Power output 0-10V (10-100% rated power)
C2_3	FREQ	Frequency output	Frequency pulse output (3.3V/10mA)
C2_5	RS485_A	Communication port	RS485(MODBUS_RTU) communication interface
C2_6	RS485_B		
C2_4	GND	Internal power ground	Public land of internal power supply (public land of C2 port)

8. Port wiring

8.1 Control input port

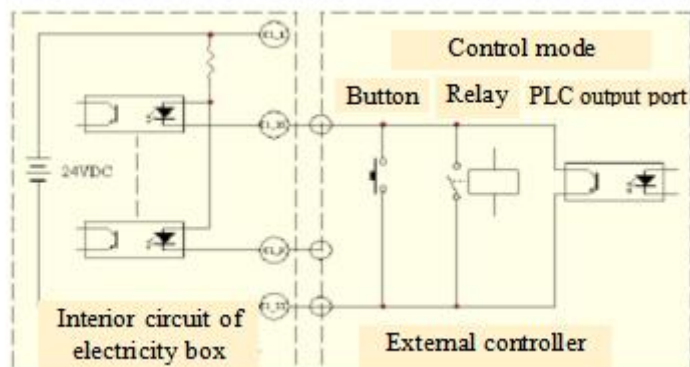

External trigger ^ ultrasonic starting

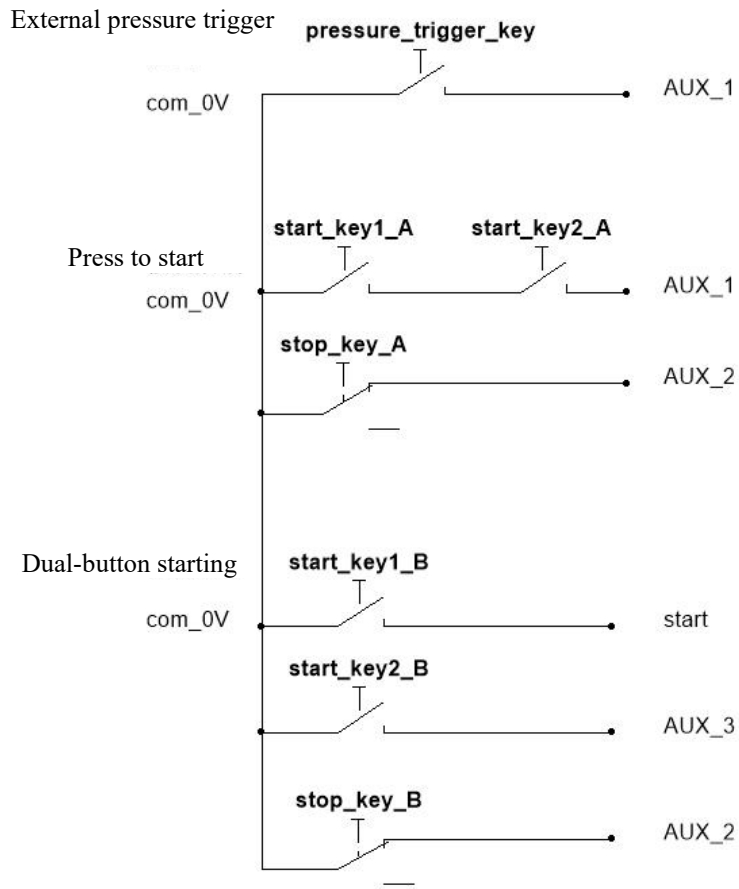

8.2 Work state output port

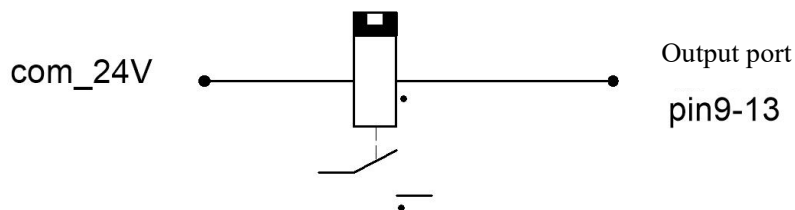
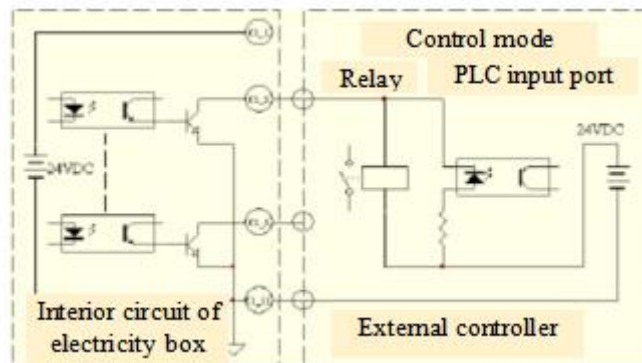

Note: The maximum driving current for 24V power input is 1A.

Please use shielded wire as signal wire, with wire diameter $\geq 0.3\text{mm}^2$ and length not exceeding 6m.

8.3 Analogue quantity input/output port

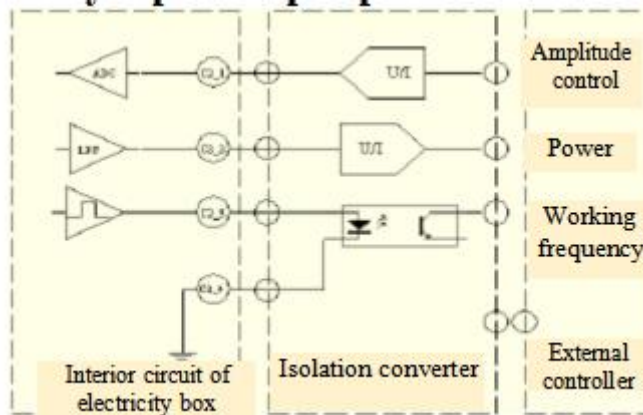

Note: Analogue quantity input and output ports have to be set with isolation switching circuits outside.
Frequency port 3.3V/10mA TTL level output

8.4 Communication port

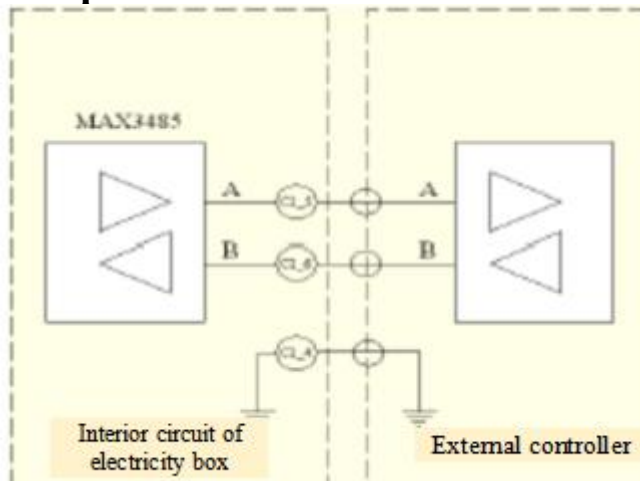

Note: RS485 communication interface shall be isolated on strong-interference site with shielded twisted pair.

8.5 HMI (human machine interface) communication port

Definition of communication wiring

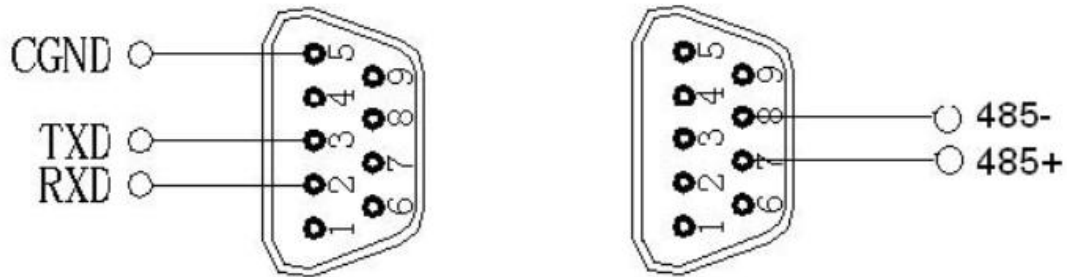

Note: Human-machine interface of the equipment applies RS485 communication, baud rate 57600, data format 8/N/1 and big-endian and little-endian.

9. Power specification

(Table 2)

Model	H60/60S				
Power	4000W	3000W	2200W	1200W	1000W
Frequency	15KHz	15KHz 20KHz	15KHz 20KHz	20KHz	35KHz
Working voltage	220VAC±10% 50-60Hz				
Rated current	12.9A	9.6A	6.5A	4.8A	3.2A
Rated power	4000W	3000W	2200W	1200W	1000W
Peak power	5600W	4200W	2400W	1800W	1500W
Fuse protection current	25A	25A	20A	15A	10A
Ambient temperature	-10 to +55°C				
Protection level	IP 20, IEC 60 529, EN 60 525				

10. Operation interface

In the following is the instruction to functions of JYD-H60/H60 interface and operations:

10.1 Password keyboard and parameter keyboard.

Password keyboard: Password input keyboard has blue background, set with keys for figures, backspace, exit and confirmation;



Parameter keyboard: Parameter keyboard has green background, set with keys for figure, backspace, resetting, exit and confirmation;



10.2 Version information interface

The interface is displayed by default when the machine is started. It skips to the welding record interface and production statistics interface when clicking any area of this interface or no operation for 6s.

The interface displays rated power, rated frequency, version and date.



10.3 Welding record interface

Click the  button in the Menu Bar to enter into this interface. The interface displays welding records, real-time welding power and data management operations.

Note: The data on the barcode scanner are shown in the area marked by the dotted line in the figure below. When the barcode scanner is not connected, there is no content in this area.

Note: Please do not shut down the equipment directly after finishing welding, and wait 40s to avoid loss of form data.



10.3.1 Data management

Click the data management button  to open the data management menu, and click the corresponding buttons according to the demand.

Clear: It starts to count from 1 again (unrecoverable), with recorded form data not deleted.

Delete record: Delete form data records (unrecoverable), with count value unchanged.

Data export: Click the button to output historical form data records and scanning data to the U disk after inserting it. The data table is named H60 + "current time". CVs. The interface will prompt "Data output is successful" when the data are output successfully.

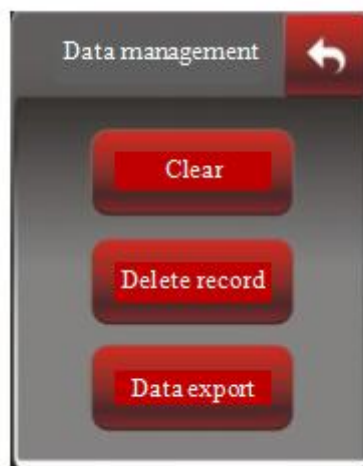

10.4 Trigger preparation interface

Click  button in the Menu Bar to enter into this interface. When entering into the interface of trigger preparation, parameter setting and quality management for the first time, the interface password which is "1234" shall be

entered.

This interface is a debugging one, which can be used to observe the power, frequency, real-time impedance and set the corresponding preset trigger mode and other setting selections. The equipment temporarily stops after entering the interface, and switches to manual mode. Press external emergency stop button for resetting.



10.4.1 Interface functions and parameter scope

- Selection of trigger mode:** I. Delay trigger: Vibration delay 0-10S;
II. Pressure trigger: External pressure switch;
- Frequency search:** Search for real-time frequency (inching, shown in green in operation).
- Ultrasonic test:** Ultrasonic function test (long-pressing, shown in green in operation).
- Trigger baseline:** The equipment goes downward after starting to reach the trigger position for automatic resetting. It is convenient for visual observation of the position of ultrasonic trigger.
- Auxiliary mode:** Customize based on customer demands;



10.5 Parameter setting interface

Click the  button in the Menu Bar to enter into this interface.

The interface can choose trigger or working mode and set corresponding parameters.



10.5.1 Interface functions and parameter scope

Amplitude mode: I. Fixed: Single-amplitude mode. Only the amplitude of section A is displayed for setting.

Setting range: 10-100%;

II. Grading: Dual-amplitude mode, displaying and setting amplitudes of Section A and B and proportion of Section A;

Setting range: Amplitude of Section A: The same as fixed mode;

Amplitude of Section B: 10-100%;

Proportion of Section A: 10-100%.

Note: Proportion of Section B is not displayed, being "100%-proportion of Section A".

Trigger mode: The same as trigger preparation interface.

Operating mode:

I. Time: weld time 0-10S;

II. Energy: welding energy 0-6,000J;

III. Time and energy.

Curing time:

Curing cooling lasts 0-10S after finishing welding.

Vibration amplitude:

Ultrasonic secondary vibration amplitude is 10-100% after curing.

Vibration delay:

Ultrasonic secondary vibration delay is 1-10S.

Vibration time:

Ultrasonic secondary vibration time is 1-10S, and secondary vibration is prohibited when it is set as 0S.



10.6 Quality management interface

Click the  button in the Menu Bar to enter into this interface.

The interface can turn on/off corresponding quality management switches and set quality monitoring scope by clicking pointer disk; The pointer shown in red refers to the start-up.



10.6.1 Interface functions and parameter scope

Period: 0-10/S.

Energy: 0-60000/J.

Note: When the maximum value is zero, it is required to set the maximum value first.

10.7 Protection function interface

Click the  button in the Menu Bar to enter the interface, and the password to the interface is "1962".

The interface can set corresponding protection parameters.

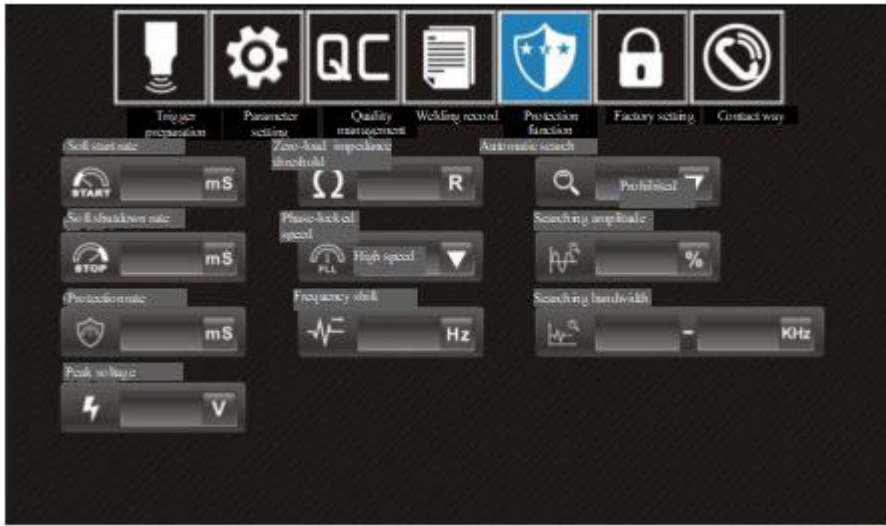

10.7.1 Interface functions and parameter scope

- Phase-locked speed:** High, fast, medium and low speed. Phase-locked rate.
- Automatic search:** Prohibited, startup, 1 time/minute, 3 times/minute, 5 times/minute, 7 times/minute, 9 times/minute. The frequency will be searched automatically in standby mode.
- Searching amplitude:** 0-1%。
- Searching bandwidth:** 13-70KHz。
- Soft start rate:** 10-2,000mS. For ultrasonic soft start speed, the larger the figure is, the longer the soft start will be.
- Soft shutdown rate:** 10-2,000mS. For ultrasonic soft shutdown speed, the larger the figure is, the slower the shutdown will be.
- Protection rate:** 1-100mS. For protection reaction speed, the smaller the figure is, the more flexible the protection will be.
- Peak current:** 1-25A.
- Peak voltage:** 500-4000V.
- Zero-load impedance:** 15-100Ω.
- Frequency shift:** 0-99Hz.



10.8 Factory setting interface

Click  button in the Menu Bar, select this sub-menu button in the pop-up window below it, and then click on Factory Settings to enter the interface. The interface password is "2005".







10.8.1 Interface functions and parameter scope

Startup mode: Button, PLC and double-button.

Type model: Standard machine model and program control model.

Display mode: Chinese, LOGO and English.

10.9 Amplitude calibration interface

Click  button in the Menu Bar, select this sub-menu  button in the pop-up window below it, and then click on Amplitude Calibration to enter the interface. The interface password is "8080".

Constant amplitude debugging steps: 1. Choose "calibration" as constant amplitude function; 2. Amplitude is set as 100%; 3. Long press ultrasonic testing button; 4. Observe system parameters and constant amplitude data; 5. Input the minimum and maximum values of observed constant amplitude data within the constant amplitude scope; 6. Choose "Allowed" for constant amplitude function.



10.9.1 Interface functions and parameter scope

- Frequency search:** The same as trigger preparation interface.
- Ultrasonic test:** The same as trigger preparation interface.
- Constant amplitude function:** Allowed, calibration and prohibited.
- Constant amplitude scope:** 20-999.

10.10 Contact information interface

Click the  button on the Menu Bar to enter into this interface.



10.10.1 Interface function

Password management: after entering the password (initial password "1234"), it can be changed or removed.

1. Password change: The passwords of trigger preparation, parameter setting and quality management interface can be changed, while the passwords of other interfaces cannot.
2. Password removal: When the passwords are removed, there is no need to input the password in the interface of trigger preparation, parameter setting and quality management. While, the password is required in case that an interface is entered for the first time when started.



Version information: Click and enter into the version information interface (startup interface).

Note: In case that a user password initial password "1234") is forgotten, please contact with the sales and agency institutions all over the country.

11. Troubleshooting

I. Abnormal communication

Fault cause:

Poor contact of communication wiring cable;
Damage on communication chip in control panel;
Unstable power supply.

Corresponding solutions:

Check communication wiring cables or combination sockets;
Replace with control panel of the same specifications;
Re-power on for resetting



II. Functional limit

Fault cause:

Users adjust control panel or other applications without permission from supplier;
Parameter setting error;
Abnormal initialization of system data storage.

Corresponding solutions:

Contact the supplier.
Reset data.



III. Poor quality

Fault cause:

Suspected defective product.

Corresponding solutions:

Press emergency stop button to reset, and check and identify workpieces, molds or equipment problems before continuously processing.



IV. Temperature rise is too high

Fault cause:

Cooling fan gets damaged or cooling air duct blocked;
Higher mold impedance, causing abnormal rising of output power.

Corresponding solutions:

Replace air fan and check cooling air duct;
Check molds, and start ultrasonic test to determine whether mold impedance is normal.



V. Abnormal load

Fault cause:

Transducer wiring cable gets loose or disconnected;
Transducer is affected with damp or positive and negative electrodes are wired wrongly.

Corresponding solutions:

Press interface resetting button to search for frequency;
Check transducer or connecting cables.



VI. Frequency overrun

Fault cause:

Mold temperature rising leads to frequency deviated beyond the maximum working bandwidth;
Loose or damaged mold leads to out-of-tune frequency locking.

Corresponding solutions:

Press interface resetting button to search for frequency;
Cool molds to normal temperature range;
Check molds, and start ultrasonic test to determine whether mold impedance is normal.



VII. Power overload

Fault cause:

Output power goes beyond the rated power scope.

Corresponding solutions:

Press interface resetting button to search for frequency;
Reduce amplitude or load (such as reducing air pressure);
Replace with ultrasonic power supply of higher power.



VIII. Over high voltage and current

Fault cause:

Peak voltage at two ends of transducer goes beyond the allowable scope;

Mold impedance is over large or overloaded.

Corresponding solutions:

Press interface resetting button to search for frequency
Check molds, and start ultrasonic test to determine whether mold impedance is

Excessive high current
Please check the mold
and retest.

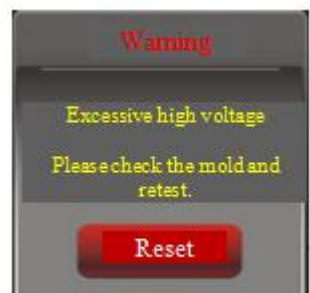

normal.

Reduce amplitude or load (such as reducing air pressure);

"Protection sensitivity" can be properly increased for accidental protection.

"Peak voltage" can be properly increased for frequent protection.

IX. Relatively higher mould impedance

Fault cause:

Mould impedance test goes beyond the allowable scope;

Overload during ultrasonic test (such as workpiece is pressed when the test starts).

Corresponding solutions:

Press interface resetting button to search for frequency

Check mould and modify;

Zero-load ultrasonic test;

"Zero-load impedance threshold" can be properly increased for loaded testing conditions (such as energy collecting bar).



X. Abnormal data

Fault cause:

Data uploaded to the barcode scanner is the same as that of the previous workpiece.

Corresponding solutions:

Scanning the bar code again;

Checking whether the data on the label of workpiece are the same;



Note: If the above corresponding fault solutions fail to clear faults, it may be fault inside generator. If so, please contact us.

12. Quality assurance

Quality guarantee for this product shall be subject to the following regulations:

Warranty only covers generator body, and warranty period starts from the Company's delivery date. Warranty period is twelve months after purchase. Faults caused by the following reasons belong to paid repair, even within the period warranty:

- 1. Problems caused by incorrect operation or repair and modification without permission;**
- 2. Problems caused by using beyond requirements in standards and specifications;**
- 3. Damage caused by falling or rude handling after purchase;**
- 4. Component aging or fault caused by using in environment not meeting requirements in the Manual;**
- 5. Equipment damage caused by foreign matters entering outside (such as insect);**
- 6. Equipment damage caused by wiring error;**
- 7. Faults caused by earthquake, fire, geomantic disaster, lightning strike, abnormal voltage or other natural disasters and causes accompanying with disasters.**

The Company is entitled to entrust others for repair for products involved in faults.

Quality warranties under responsibility of the Company, using in China:

- a. Warranty within twelve months after delivery.**
- b. All sales and agency institutions of the Company all over the country can provide after-sales services.**

13. Additional Explanation

About disclaimer:

- 1. The Company does not undertake responsibilities caused or induced by using the product violating the Manual.**
- 2. The Company does not undertake responsibility for compensation against losses or impacted and secondary damages caused to you by faults of the product.**

Notice for use:

The Company undertakes lifelong responsibilities for the product, and provides with all services related to the product.

Although the product is designed and manufactured under strict quality control, please be sure to ask us about using purposes where its fault or mis-operation may endanger human body or other lives.

14. Contact Us

Hotline: 0769-83506468

The Company reserves the right to modify the Manual without previous notice; If any question or problem, please contact with us in time. Your suggestions are warmly welcomed.